

# Laser printer is within reach.

Simple integrated design ensures smooth integration into your production line, intuitive user interface and built-in wizard, which can significantly reduce operator training and make you master it quickly.

---

## High quality products, reasonable price

Provide high quality at a reasonable price to make laser technology universal.

---

## Precise design and flexible use

German technology and excellent component design ensure a reliable and high-quality system that can handle various application scenarios.



## Optical fiber 20 / 30 / 50W series specification / laser inkjet printer

Provide high-quality and reliable laser system, which is deeply trusted by customers in many countries / regions.



## Optical fiber 20 / 30 /50W series specification / laser inkjet printer

### Endless possibilities and excellent technology

It allows you to automatically scan the data of multiple processes from the production line or from the external production line, so that you can easily complete the automatic inspection of multiple process data sources, such as th.



#### Communication software

Carry out data communication through serial port or network port, and bring its own single machine and dual machine coding software.



#### Visual culling

With its own visual communication protocol, users can choose this function for seamless integration.



#### Remote control

It can be linked to the host computer through Ethernet to realize remote operation in different places.



#### Degree of protection

The overall protection grade of the controller reaches IP55.



◆ main technical parameters of UV series:

project	Parameter table	GX-20W	GX-30W	GX-50W
characteristic	Machine material	All aluminum sandblasting oxidation		
	Laser	The service life is more than 100000 hours		
	Laser wavelength	1064nm		
	output power	≥20W	≥30W	≥50W
	Marking speed	≤12000mm/s		
	controller	10.2 inch touch controller		
	Cooling system	Air cooling		
parameter	Focus lens	165mm		
	Minimum linewidth	0.012mm		
	Repetition accuracy	0.003mm		
	Marking range	110mm×110mm(optimal)		
	Positioning mode	Blue light indication		
	Number of rows	Any line within the marking range		
	Production line speed	0~130m/min (depending on the material)		
Software	Multilingual	English, Spanish, German, Chinese, Russian, Arabic, etc		
	jurisdiction	Multi user management authority		
	operating system	Linux system		
	Inkjet mode	Static, analog, encoder		
	Reserved signal	Start, print status, finish, fault		
	data protection	With power failure data protection energy		
	monitor	Provide overspeed alarm function		
	De crossing	Automatic removal of intersections		
	Coding software	Single and double machine code sending		
Support type	typeface	Chinese and English, numbers, traditional, etc		
	file format	BMP/DXF/HPGL/JPEG/PLT		
	bar code	CODE39、CODE128、CODE126、QR		
Servicing parameters	Power Supply	220V/50HZ		
	Power consumption	400W		
	Net weight of machine	28kg		
	Overall dimension	nose: 500mmX103mmX110mm Control box: 416mmX170mmX267mm		
environment	requirement	External temperature 0℃ — 45℃; humidity ≤95		

◆ quality standards implemented

Serial number	name
GB 7247-87	Radiation safety of laser products
GB10320-88	Electrical safety of laser equipment and facilities
ISO9000-3	International software standards
GB/T12123-89	Sales packaging procedure
IEC 536	Protection equipment against electric shock

◆ main configuration list:

number	Subsystemname	brand	model	quantity	Place of Origin
1.	Laser	Wuhan Ruike	1064-20QS/30QS/50QE	1	China -wuxin
2.	Galvanometer	Shenzhen-ZBTK	ZB2D10C1064	1	China - Shenzhen
3.	Field mirror	crystal lattice	JGZL1-1064-160-110	1	China - Shenzhen
4.	Power Supply	Taiwan Mingwei	S350-24W	1	Taiwan
5.	software system	Shenyang baichuang	10.2 External	1	China Shenyang
6.	photoelectricity	Xinshe electric	FZ2-22N	1	China Zhejiang
7.	Synchronizer	Changchun side	38S6-2500	1	China Changchun
8.	focusing	Shenzhen-ZBTK	ZB2D10C1064	1	China - Shenzhen
9.	wave filter	YUNSANANDA	CW2B-10A	1	Taiwan
10.	Bracket	self-control	SY02415-1500	1	China

◆ attached accessories and relevant data:

number	Subsystemname	quantity	remarks
1	Laser machine equipment	One	Random accessories
2	Control system	One	Random accessories
3	Photoelectric inspection switch	One	Random accessories
4	Synchronizer	One	Random accessories
5	Flight support	One	Random accessories
6	Windows Debugging Tools	One	Random accessories
7	Mechanical and circuit diagram	One each	Random accessories
8	instructions	One each	Random accessories

◆ Overall dimension:

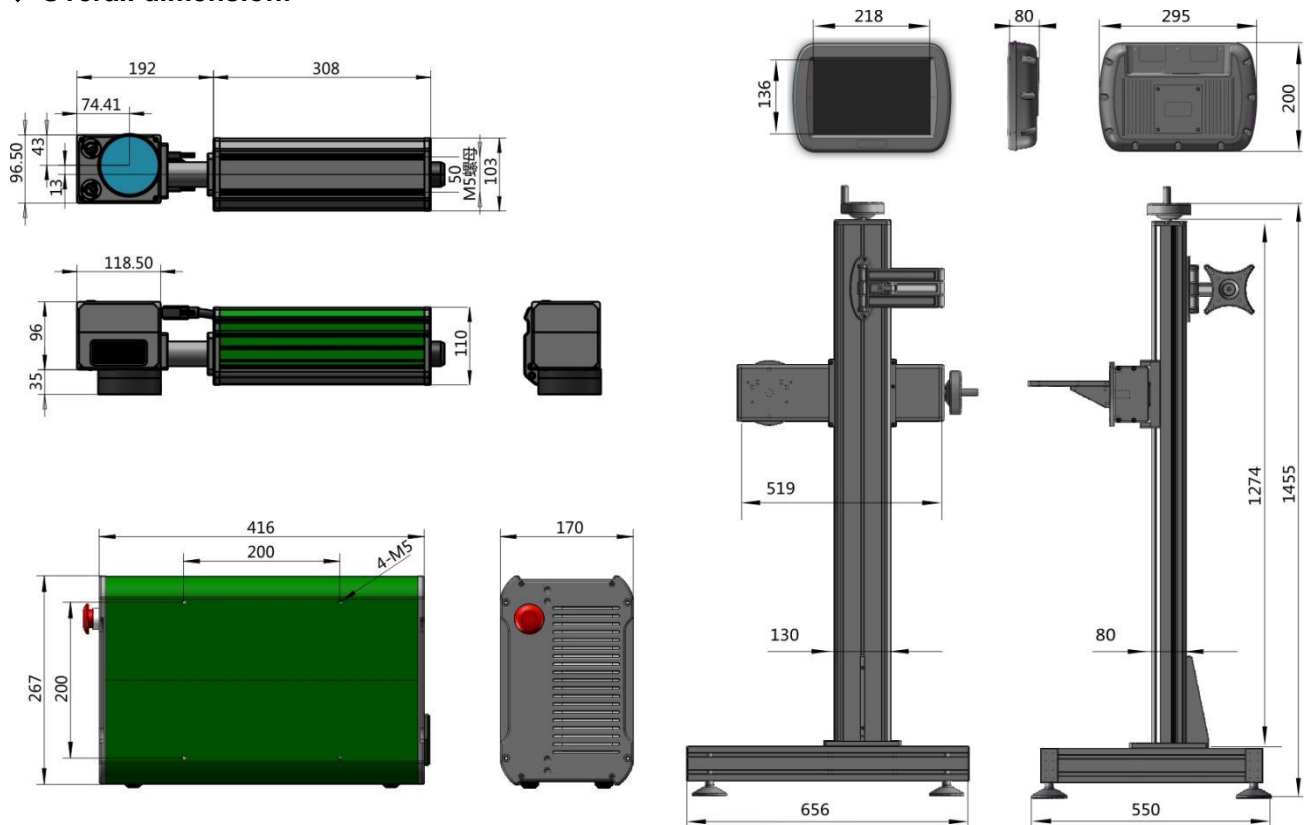



# Take peace of mind as the standard

Concise - the large-scale "WYSIWYG" color touch screen provides intuitive icons and shortcuts to ensure user-friendly operation. And other security functions are fast and easy to use, and information loading and Ethernet access can be easily completed through the standard USB port.

It can meet your development needs and easily update your marking machine power without changing the whole system. High flexibility, laser scheme can process various workpieces (brittle, soft, hard, surface removed)

-20W: economic scheme, matched with conventional th production line.

-30W: multi purpose high-performance solution for high-speed th production line.

-50W: powerful scheme, suitable for applications requiring high speed and depth. It can be used for engraving.

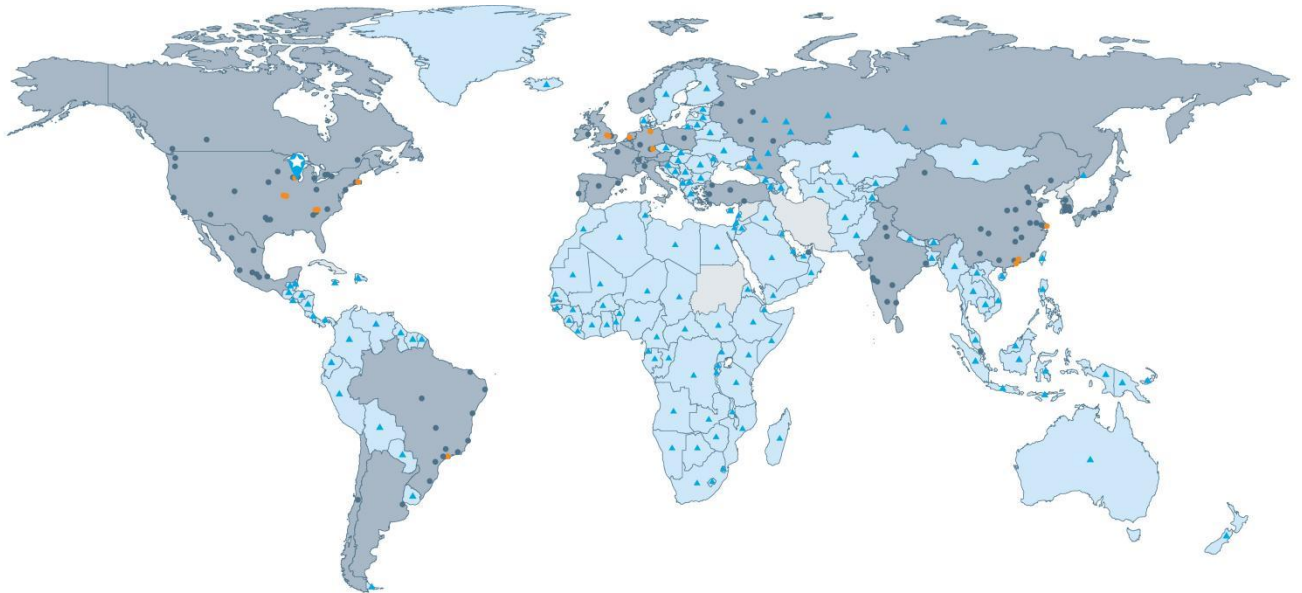

company:  
Address:  
Telephone:  
Email:  
website:  
contacts:

The company reserves all rights, and continuous optimization of design scheme is the same policy.

Sy20210634  
br-5008-sb-fw-23  
Patent pending

